

# SPECIFICATIONS

## 2-HOUR VERTICAL LEGAL FILES



**FIREPROOF INSULATION** is Thermocell II, reinforced by a 1" by 2" lattice made of 14-gauge galvanized welded steel wire, providing complete peace of mind from fire, impact, or explosion.

**FIELD REPLACEABLE STEEL PANELS** can easily be replaced in the event that any panel is damaged.

**FINISH** is an environmentally-friendly electrostatic powder coating applied to all sides, including bottom. The finish is scratch-resistant, providing a lifetime quality appearance. Standard colors available include: parchment, tan, taupe, brown, black, sand, champagne, platinum, and pewter.

**DRAWER BODIES** are built with high sides for use with hanging folders – no additional frames are needed. Each file includes 1 follower block per drawer.

**DRAWER SUSPENSIONS** are maintenance free.

**DRAWER LOCKS** are UL®-listed Medeco high-security key locks.

**DRAWER PULLS** are surface mounted to allow for extra insulation inside the drawer heads.

**INSULATION BETWEEN ALL DRAWERS** makes each drawer a separate insulated container.

**WATER RESISTANCE** means files are designed to prevent water damage resulting from sprinklers and fire hoses.

**2-POSITION DRAWER CATCH** allows access to certain drawers while others remain locked.

**DRAWER HEADS** are formed of welded steel and filled with fireproof insulation, and are field replaceable.

**UNDERWRITERS LABORATORIES® (UL®) FIRE & IMPACT RATING** on all file cabinets. These models carry the 2-Hour Class 350 Fire with Impact UL label. Tests include 2 hour exterior fire exposure at 1850°F, a 2000°F explosion test, and a 30 foot drop to test impact integrity.

**OPTIONAL UPGRADES** are available to enhance your file's appearance or functionality. Upgrades available include custom color finishes, standard lock options, casters, and interior options such as hanging folder frames, document inserts, trays, and inner drawers.

**FIREKING'S 3-YEAR LIMITED WARRANTY** includes parts and labor provided by a factory authorized technician. Beyond the base warranty, if your FireKing file is ever required to protect your documents in a fire and its protective properties are damaged, FireKing will replace the file free of charge.

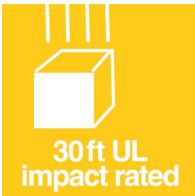

### Filing Arrangements:

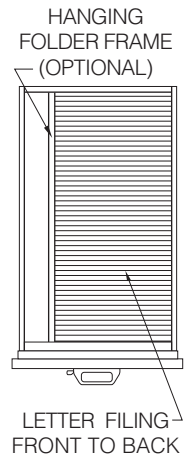
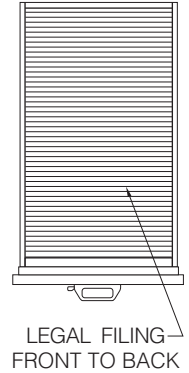

### SIDE VIEW:

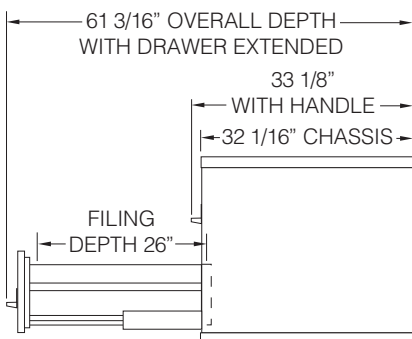

### MODEL 2-2130-2:

592 lbs (avg. ship wt.)

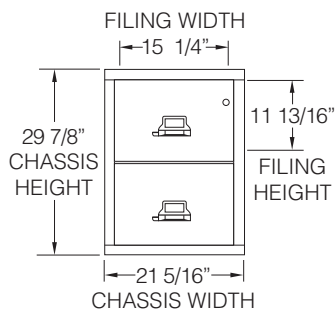

Dimensions  
± 1/16 inch

### MODEL 3-2144-2:

651 lbs (avg. ship wt.)

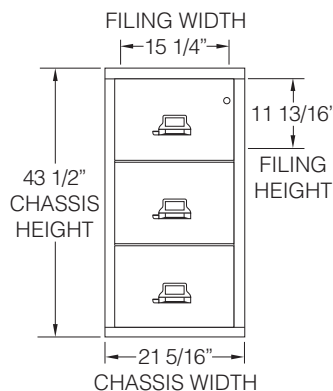

### MODEL 4-2157-2:

1021 lbs (avg. ship wt.)

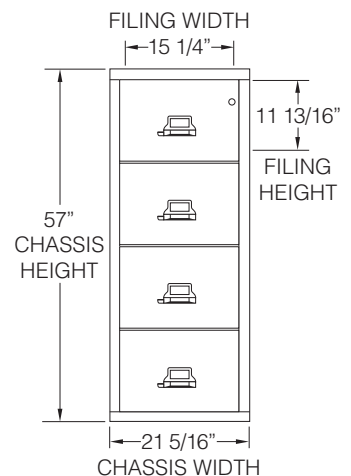

FireKing Security Group  
101 Security Pkwy • New Albany IN 47150  
800.457.2424 / 812.948.8400  
www.fireking.com